

Ceiling Fans That Wobble

Do you have a ceiling fan that wobbles every time you turn it on? This is a common occurrence that can easily be fixed, without having to call a specialist. First, it must be determined if the fan is rocking or wobbling. A fan that is rocking CAN NOT be balanced, and the cause is a problem with the installation. Let's look at the difference between a rocking fan and a wobbling fan. A rocking fan has a side to side, either vertical or horizontal, movement and a wobbling fan has an orbital movement of the fan body. This can be easily viewed by taking a 12" piece of string with a weight attached. Tie or tape the string to the bottom of the fan or light kit. Turn the fan on at medium speed. As the fan gets up to speed the weight on the string will start to move. If the weight is moving side to side the fan is rocking as shown in (Fig#1). If the weight is moving in an orbital, egg shape movement, the fan is wobbling, as shown in (Fig#2).

Now, let's look at the causes of fan wobble. Some installation problems also can be the cause. One potential problem is that your ceiling fan has loose screws. Considering that all ceiling fans have several screws that are used in the assembly of the fan, it would not be uncommon for some of them to come loose. Start by tightening all of the screws used to hold the blades to the blade irons and where the blade iron fastens to the motor as shown as location # 1 (Fig #3). If this does not work, try securing the down rod to the fan motor as shown in location #5 (Fig #3). Next, tighten the screws used to secure the down rod to the mounting ball, the screws for the mounting bracket, and finally, the screws that secure the ceiling box to the ceiling, as shown in locations #4 and #6 (Fig #3). These steps should resolve the problem. If the wobble continues, try tightening all other screws. Listed below and shown in (Fig#3) are all other locations on your ceiling fan that should be checked for loose screws.

Let's check each of these other causes of wobble in order. First, are your blades flat and straight? This is easy to check. Just get up on a ladder and look down the length of each blade, as shown in (Fig #4) on the next page. Is each one nice and flat? There should be no bend and no twist to the blades. Wooden blades contain water. Over time, the water can evaporate until the moisture content of the blades is equal to the moisture content of the air in your home. Depending on how the blade was sliced from the original piece of wood,

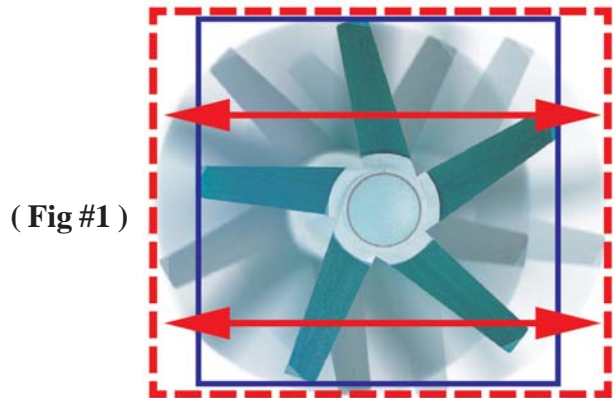

Movement of a Rocking Fan.

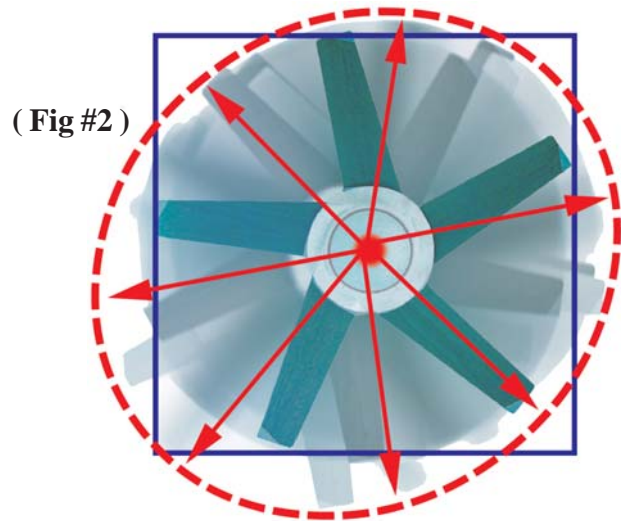

Movement of a Wobbling Fan.

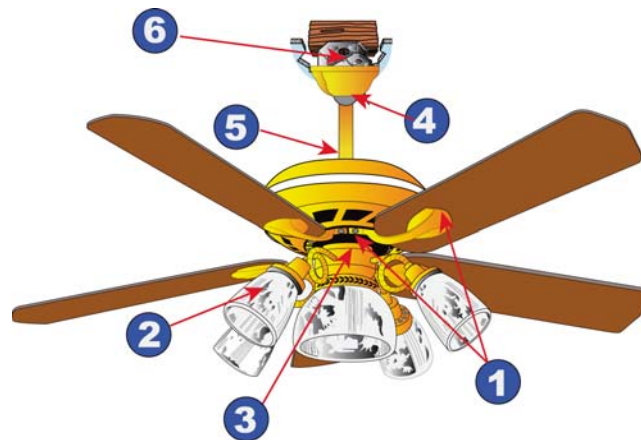

(Fig #3)

it may dry perfectly flat or it may warp or twist. If one or more of the blades is warped or twisted the entire set will need to be replaced. This is because your blades are weighed to within 1 gram of each other. You cannot just replace one blade or one blade holder.

Another way to check for warped blades is to remove all of the blades from the blade irons. Stack the blades on top of each other and look for gaps. If the blades do not lay flat, they are warped. In some cases a fan may not wobble with warped blades. If after tightening screws and balancing the blades the fan still wobbles, a new set of blades should be purchased to replace the warped set.

Using a measuring device, as shown in (Fig #5) (ruler, yardstick, or even a piece of stiff paper and pencil) measure the distance from the tip of one blade to the ceiling. Leaving the measuring device in place on the ceiling, carefully rotate the fan blades (if it is a ball mounted fan be sure not to change the angle at which it hangs) so you can measure the next blade. Repeat with the remaining blades. Most likely you will find one or two blades either too high or too low.

Check the blade irons for cracks, especially near where the blade iron widens to accept the blade. If you notice ANY cracks, do not proceed with the next step; REPLACE the complete set of blade irons! If a blade iron is bent, do NOT attempt to bend it back. You might crack the blade iron causing the blade and blade iron to fly off the fan and possibly injure someone. Again, you will need to REPLACE your complete set of blade irons with a new set.

Another possible cause for wobble has to do with the blade set. Ceiling fans have matched sets of blades, each with only a one-gram difference. Fig #6 shows how to check blades for a weight problem. Tilt the fan body as shown, and the blade with the most weight will rotate to the bottom. It is possible that when the fan was installed, the blades were intermixed. In fact, this problem happens quite often, especially if you are installing several fans in the same room or even the same house. If you believe this may be the cause for your fan wobble, remove the blades and use a gram scale to weigh each blade. Then divide them into sets so you have alternating weight, thus creating smooth movement.

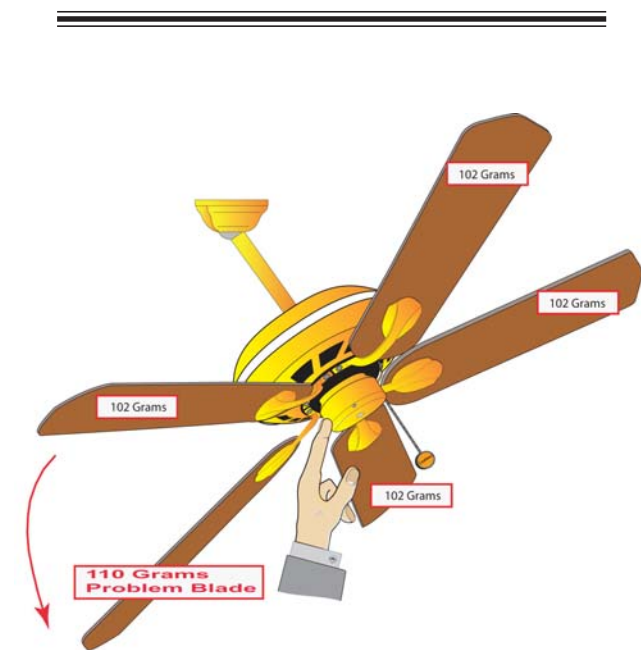
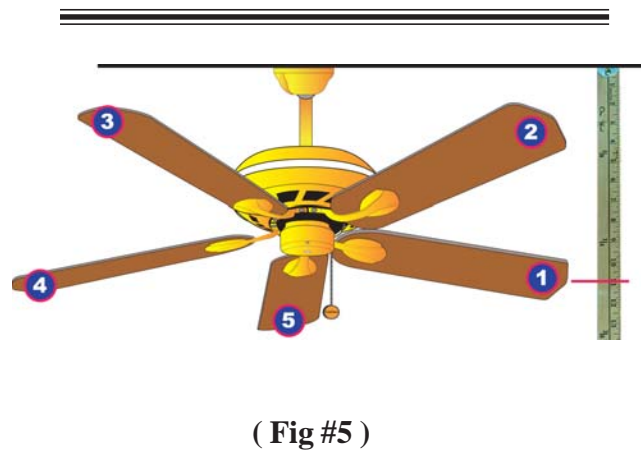
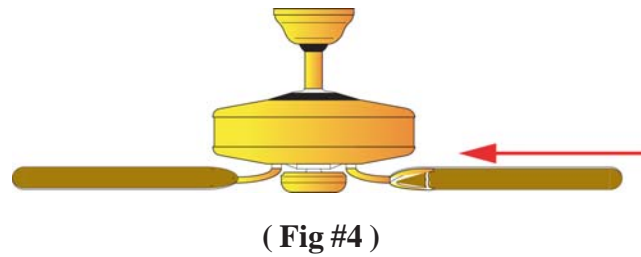

Wobbling and Rocking Fans - (CONTINUED)

Casablanca Fan Co. - Factory Service Department - Technical Library

If the options previously mentioned have not worked, you can try balancing your ceiling fan. There are two methods for balancing your ceiling fan. The first method is to number each of your blades as shown in (Fig #7A). Then remove the blades that you have marked 1 and 4, as shown in (Fig #7B), from the fan motor. Swap the location of these two blades as shown in (Fig #7C) and see if the wobble problem is corrected. If the wobble continues, replace the first two blades, and then remove the second two blades, such as blades numbered 5 and 3, and swap those two. If this still does not correct the wobble, try the next balancing method described below.

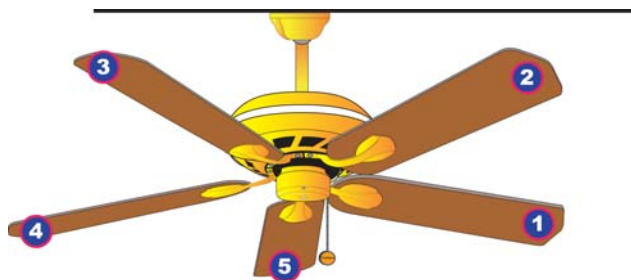

(Fig #7A)

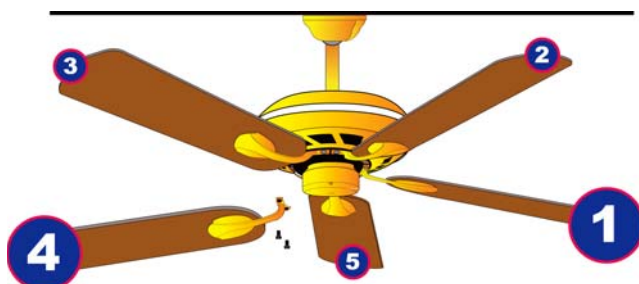

(Fig #7C)

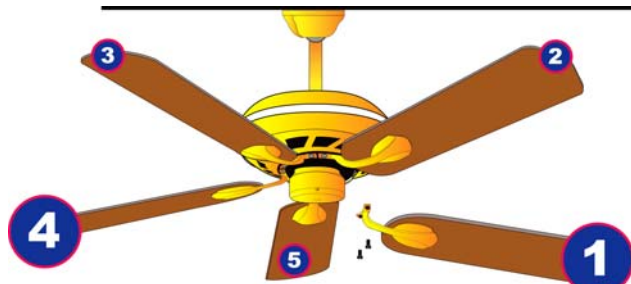

(Fig #7B)

The second method for balancing is Dynamic Balancing, which involves 'counter-weighting' by using a small weight opposite to the point of wobble. Using this method, you can eliminate the wobble in almost all cases. The procedure requires much trial and error, so be patient. Determine which fan speed causes the most wobble. This will almost always be the highest speed. Turn the fan off. Start by checking to see if one of the blades or blade irons is heavier than the others. This is easy to do by tilting the fan, as shown in (Fig #8). The heaviest blade will slowly swing to the bottom. Select any one blade on the opposite side of the fan and place the balance clip half way between the blade tip and blade holder on the rear edge of the blade, as shown in (Fig #9).

CAUTION: Be careful to stay clear of the blades when running. If the clip is not secure, injury may result from the clip flying off. Turn the fan on (use the speed that causes the most wobble). Observe if the wobble is better or worse. Turn the fan off and move the clip to the next

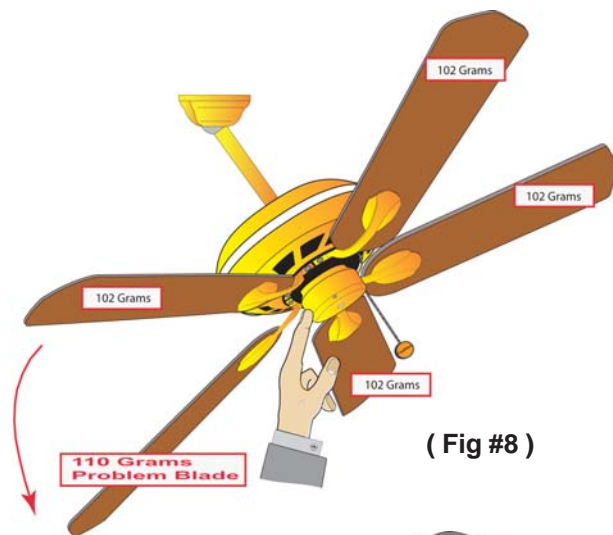

(Fig #8)

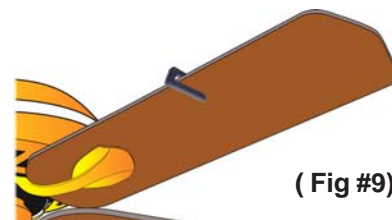

(Fig #9)

Wobbling and Rocking Fans - (CONTINUED)

Casablanca Fan Co. - Factory Service Department - Technical Library

blade. Do the same for all blades and note on which blade the clip reduces the wobble most. Place the clip on the blade which showed the most improvement. Then, to find the position which most improves the wobble, move the clip in and out along the blade, by trial and error, as shown in (Fig # 10). Once the exact position is determined, you will need to reverse the fan. If the wobble has stopped in both directions, place a weight on top of the blade, on its centerline, directly inline with the clip as shown in (Fig #11) . Peel the paper off of the back of the weight and press firmly to ensure that it is securely attached to the blade. Remove the clip and discard, as shown in (Fig #12) . Turn the fan on. No wobble? Congratulations, you're done! Still some wobble in one direction or the other? You may have to fine tune the balance of your fan . Fine tuning is covered on the next page.

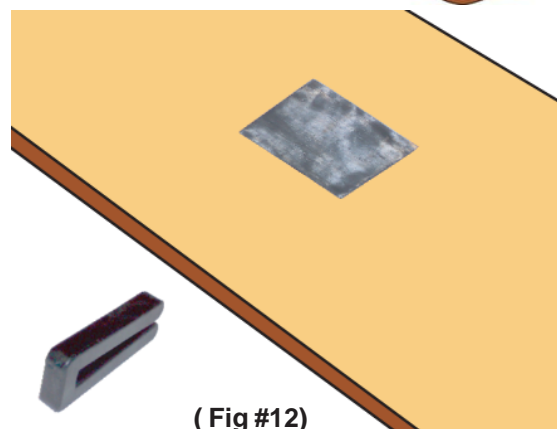
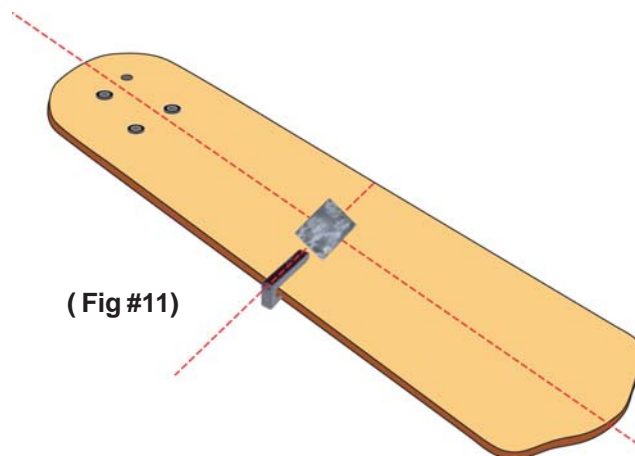
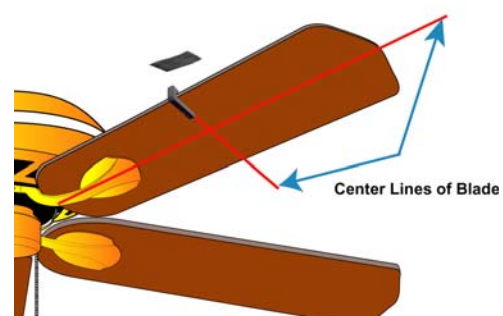
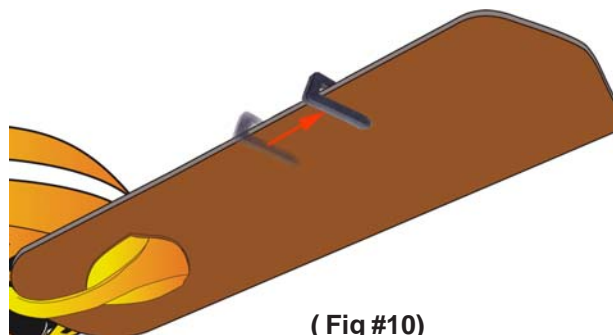

Wobbling and Rocking Fans - (CONTINUED)

Casablanca Fan Co. - Factory Service Department - Technical Library

FINE TUNING YOUR CEILING FAN:

The procedure of fine tuning the balance of your ceiling fan requires a little more trial and error. So again, be patient, you are almost done. Turn the fan on (use the speed that causes the most wobble) in either the forward or reverse direction.

Start by placing the clip back on to the blade. Position the clip on the center line of the weight as shown in (Fig #13) and remove the weight. Using a ruler, move the clip 1" (one) inch towards the tip of the blade, as shown in (Fig #14). CAUTION: Be careful to stay clear of the blades when running. If the clip is not secure, injury may result from the clip flying off. Turn the fan on (use the speed that causes the most wobble). Observe if the wobble is better or worse in both directions. If the wobble has worsened, you will have to move the clip in the opposite direction. Turn the fan off , again using a ruler move the clip 1 1/2" (one and a half) inches back towards the blade holder, as shown in (Fig #15). Turn the fan on again, test in both in directions. No wobble? Congratulations, you're done! Place the weight back on the blade and press firmly to ensure it is securely attached. Remove the clip and discard as shown in (Fig #16) .

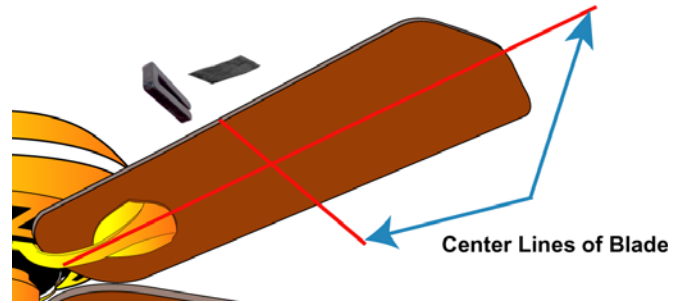

(Fig #13)

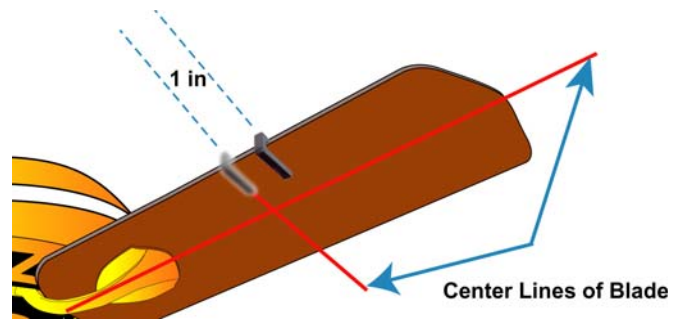

(Fig #14)

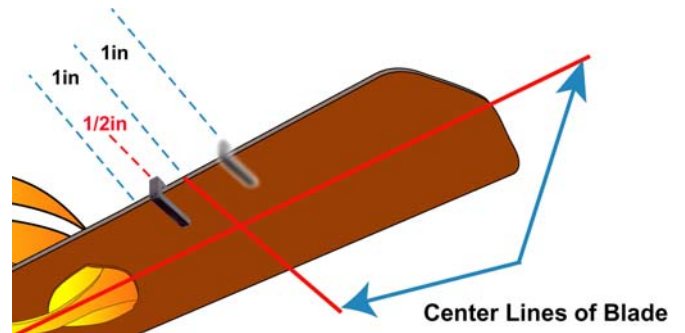

(Fig #15)

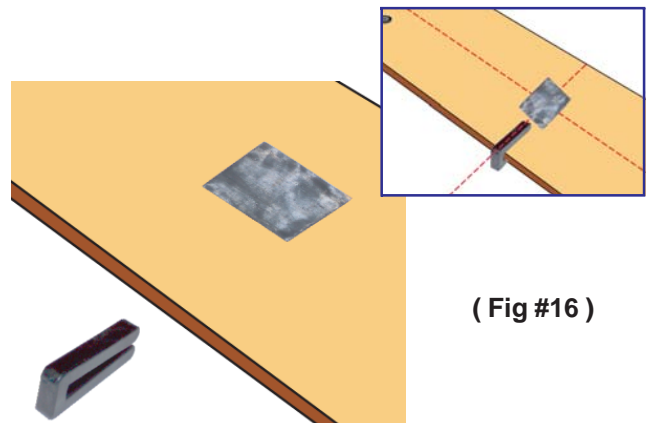

(Fig #16)

Wobbling and Rocking Fans - (CONTINUED)

Rocking Fans and their causes

Rocking Fans and their installation problems:

Now let's look at a few of the many installation problems that can cause fans to rock. The first problem we will look at is the one that is most often overlooked. When sizing up a room for a ceiling fan installation there are many things that should be considered. Such as, how many fans the room will need? On a high ceiling, as show in (Fig #1), how far from the ceiling should the fan be extended? What kind of fan should I get? You need to ask your self these questions: Is there any thing or any condition in the room that will keep the fan from operating properly? Such as, What happens if the down rod is to short? What happens if the Air Conditioning vent is blowing on the fan at the same time fan is running? Is the ceiling box that the fan is attached to installed correctly? These three items are the main causes of fans that rock.

Installation begins with choosing where the fan should be located. In almost all homes, the fan is installed in the center of the room, replacing a central light fixture. This location provides a smooth air flow to most of the room. Being a flat or a vaulted ceiling, the length of the downrod that the fan is hanging from can also change the airflow to the room and the performance of the fan.

We will start with a vaulted (cathedral) ceiling or sloped ceiling. For maximum performance and best appearance in this application a downrod pole should be used. The airflow of the fan should be smooth as shown in (Fig #2A) and not obstructed as shown in (Fig #3). When the pole is to short, as shown, this will cause the airflow to be reflected. The airflow being reflected will cause a back wash on to the fan causing the fan to rock. You need at least 12" between the ceiling and the top of the fan blades for proper airflow. Having 18" is better, if the space is available, as shown in (Fig #2B). Casablanca offers standard poles in increments of 6" up to 5'. Custom poles are available in lengths up to 10'.

NOTE: Fan may rock, wobble or vibrate if pole length is not long enough and inside blade is to close to downslope or side wall. Extending pole length will usually solve problem.

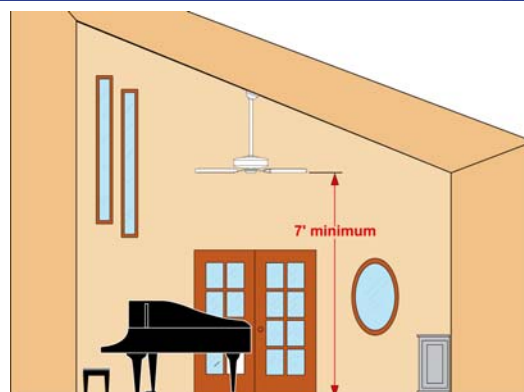

(Fig #1)

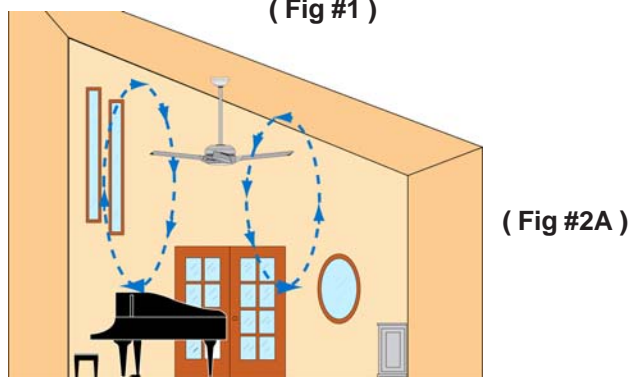

(Fig #2A)

You need at least 12" between the ceiling and the tops of the fan blades for proper airflow. Having 18" is better if the space is available.

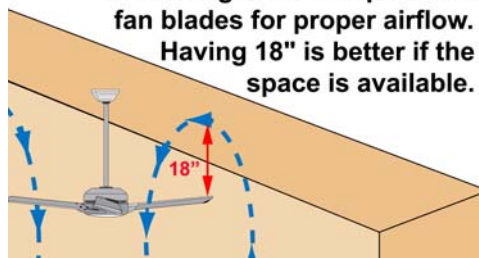

(Fig #2B)



(Fig #3)

Wobbling and Rocking Fans - (CONTINUED)

Casablanca Fan Co. - Factory Service Department - Technical Library

In a room with a flat ceiling, the airflow of the fan should again be smooth, as shown in (Fig # 4), and should not be obstructed, as shown in (Fig # 5). When the fan is installed too close to a wall or large object, as shown, it will cause the airflow to be reflected. The airflow being reflected will cause a back wash on to the fan causing the fan to rock. When it is necessary to install a fan in the corner of a room or near large objects, the tips of the blades need to have 18" inches or more of clearance from the walls or any large objects. If the fan blades are within several inches of the ceiling or a wall, rocking or wobble can occur due to turbulence of air near the tips of the blades. Moving the fan further away from the wall or object may decrease the amount of movement. With the 18" inch clearance at higher speeds you may still get a small amount of rocking or shaking.

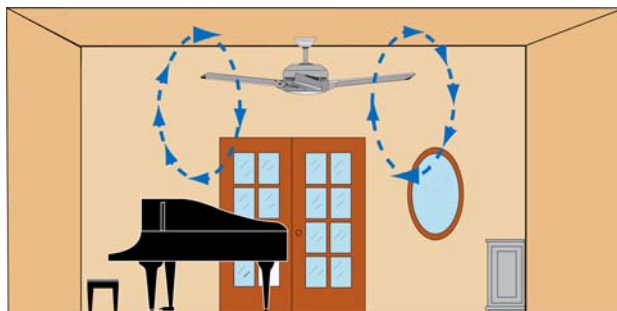

(Fig #4)

On a standard installation there can be times and conditions where your fan will shake or even rock and there is nothing wrong with your fan. One of these conditions can occur in the Winter mode. Winter mode is when the air is being blown in the upward direction, as shown in (Fig # 6). When the fan is being used in the Winter mode or in the upward airflow direction, airflow can be compressed against the ceiling, as shown in (Fig # 7). Air compression can cause light weight fans or fans with large, heavy light kits to shake or rock. This mode is intended to be used to provide draft-free recirculation of heated air, and only the lowest or lower speeds should be used. If higher speeds are used it can cause a draft or cause compression as described above.

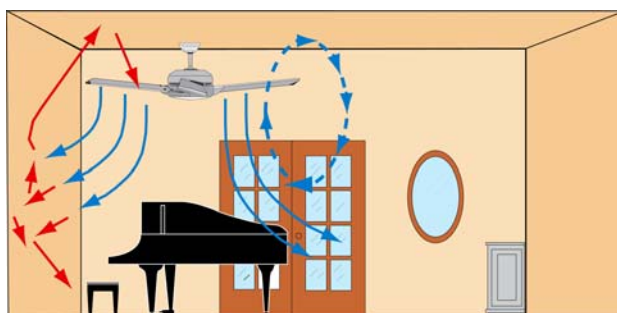

(Fig #5)

AIR CONDITIONING DUCTS:

Let's take a look at Air Conditioning ducts. If the fan is hanging at the same height as an Air Conditioning duct, as shown in (Fig #7), when the air or heat comes on the air that is coming out of the duct can disturb the air flow of the fan. This can cause the fan to rock side to side or shake when both the fan and the AC is on at the same time.

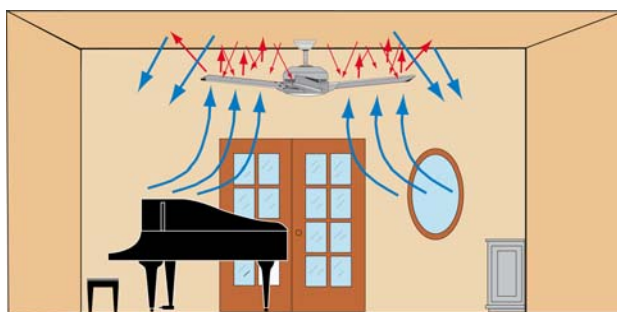

(Fig #6)

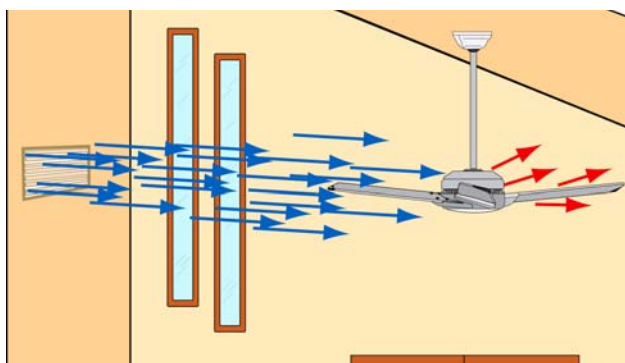

(Fig #7)

Wobbling and Rocking Fans - (CONTINUED)

Ceiling Box:

The ceiling box, shown in (Fig #1), is one of the most common causes of rocking fans, and sometimes is the hardest to detect. Before installing a ceiling fan the ceiling box should be inspected to see if it meets both state and city building codes. Most of the time in the center or some where on the box it will be stamp "CEILING FAN BOX". Inspect the ceiling box by pushing the box side to side and pushing up and pulling down on the box to make sure that it is tight. If the box moves, the box will need to be replaced, or tighten it by adding a support stud, as shown in (Fig #3). Remember that your ceiling box should meet both state and city inspection codes.

If the box is mounted to the side of the joist or beam, as shown in (Fig #2), your ceiling box will need to be replaced. Some of the larger and heavier fans require a secondary support or means of support to be added to the ceiling box, as shown in both (Fig #3) and (Fig #4)

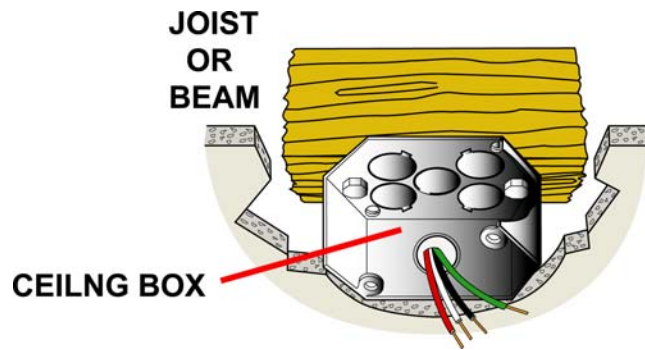

(Fig #1)



(Fig #2)

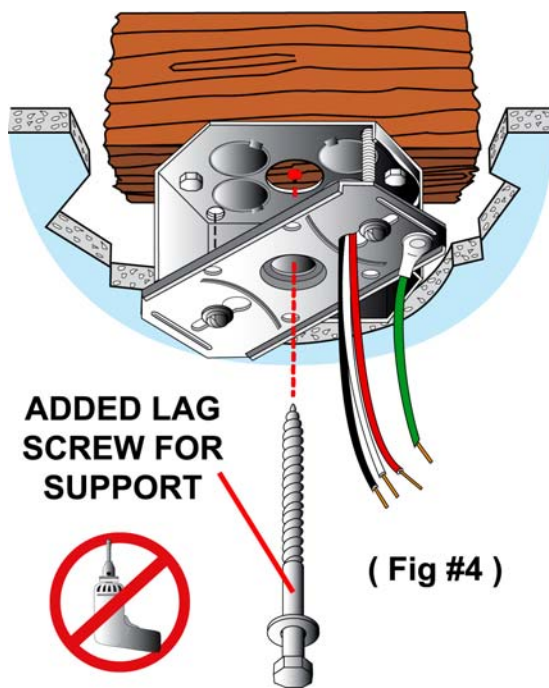

(Fig #4)

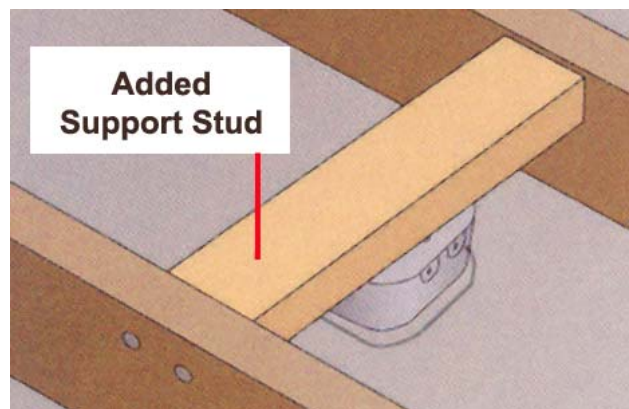

(Fig #3)

Wobbling and Rocking Fans - (CONTINUED)

Ceiling Box Replacement:

When replacing or installing a new ceiling box, for easy replacement and installation the Super Fan Brace, shown in (Fig #1A and Fig #1B), is one of the most popular fan braces used in the industry. The Super Fan Brace is rated for up to 70 pounds for ceiling fans and up to 100 pound for chandeliers. It can be positioned between ceiling joists 16" to 24" apart. The Super Fan Brace is easy to install when replacing an existing ceiling box. It is so easy, that going into the crawl space of the roof will not be necessary. Once the old ceiling box has been removed, from within the room, as shown in (Fig #2), the Super Fan Brace can be inserted through the hole in the ceiling for easy installation. This type of fan brace provides a solid mounting platform for your ceiling fan and has the secondary support system built into it as shown in (Fig #3).

Before installing the canopy or hanger for the fan, make sure that the ceiling box and the crossbar mounting bracket are centered and tight in the ceiling, as shown in (Fig #4). The canopy should fit tightly against the ceiling, with the full 360 degrees of the canopy fitting tightly against the ceiling with no gaps or visual clearance between the drywall of the ceiling and canopy edges. Any movement in this part of the installation of a ceiling fan will cause the fan to rock. If you have 1/8 inch of movement, by the time this amount of movement gets to the bottom of the light kit, you could see as much as 2 inches of side to side rocking of the fan, as shown in (Fig #5).



(Fig #1A)



(Fig #1B)

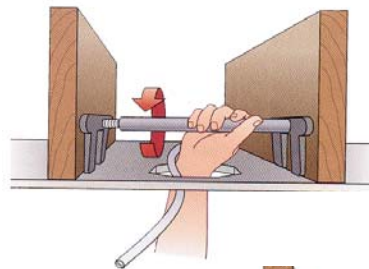

(Fig #2)

(Fig #3)

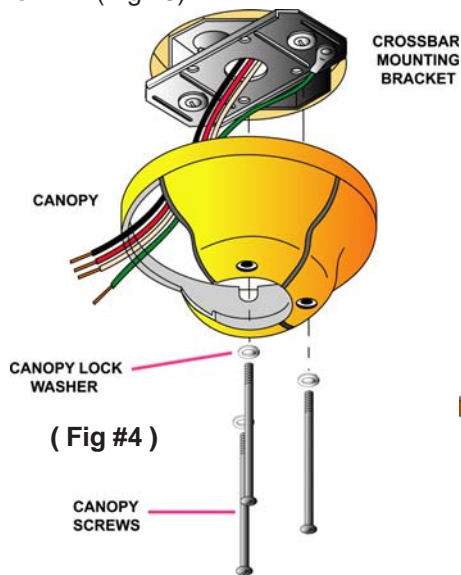
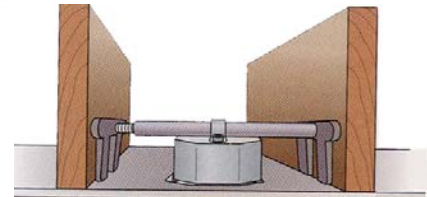

(Fig #4)

1/8 INCH CANOPY MOVEMENT

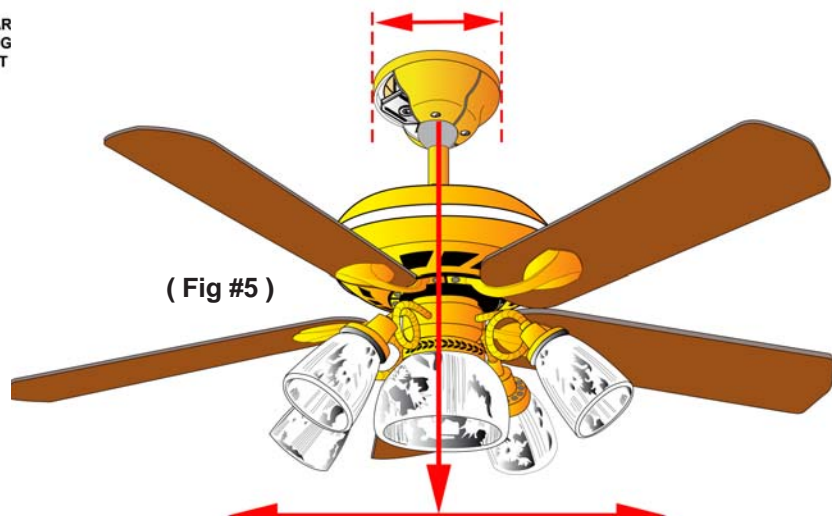

(Fig #5)

CAN CAUSE AS MUCH AS 2 INCHES OF ROCKING

Wobbling and Rocking Fans - (CONTINUED)

Casablanca Fan Co. - Factory Service Department - Technical Library

Ceiling Fans Mounted on a Wooden Beam:

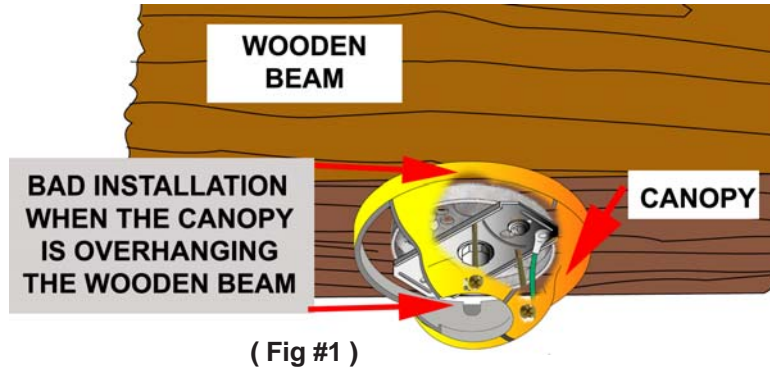

(Fig #1)

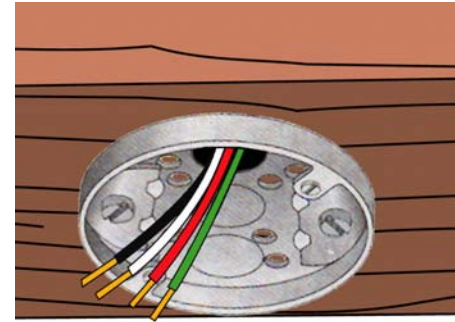

(Fig #2)

Narrow Wooden Beams:

If your fan is hanging from a wooden beam and is wobbling, before you try to balance it you might want to see if the fan is mounted correctly. When hanging a ceiling fan from a wooden beam, as shown in (Fig #1), it is very important that the canopy or fan holder is not hanging over the edge of the beam. This will cause the fan to rock, and may cause the fan to fall. If the canopy or hanging support bracket is hanging over the edge of the beam, as shown in (Fig #1), you will need to fix this problem. Your fan is rocking and not wobbling. Rocking fans CAN NOT be balanced. When mounting a ceiling fan to a beam, as shown in (Fig #2), you will need to install a support plate under the pancake box, as shown in (Fig #3). Installing a support plate under the pancake box will give the canopy a platform to set on. This will let the 360 degree edge of the canopy rest on the support plate, giving your ceiling fan a very solid mounting surface, as shown in (Fig #4).

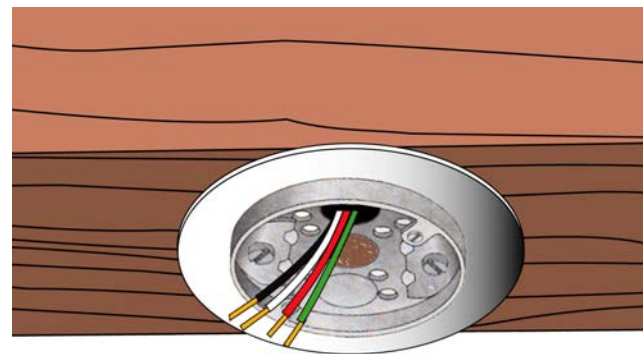

(Fig #3)

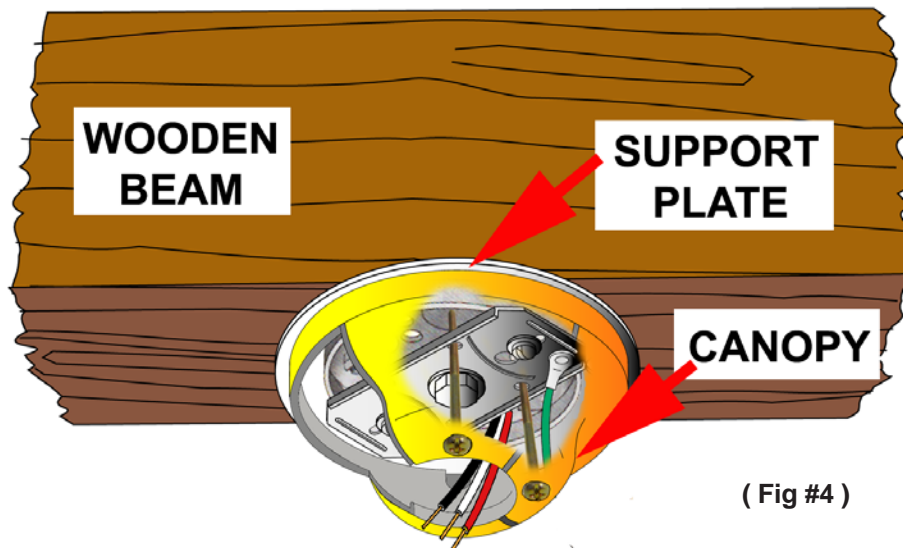

(Fig #4)

Wobbling and Rocking Fans - (CONTINUED)

Casablanca Fan Co. - Factory Service Department - Technical Library

Ceiling Fans Mounted on a Wooden Beam:

Full Size Wooden Beam:

If your fan is hanging from a wooden beam and is wobbling, before you try to balance it you might want to see if the fan is mounted correctly. When hanging a ceiling fan from a wooden beam, as shown in (Fig #1), it is very important that the canopy is mounted flat to the wooden beam. The height of the pancake box may prevent the fan from hanging correctly in the canopy, causing a gap between the wooden beam and the canopy. If the height of the pancake box is more than 1/4" (inch) as shown in (Fig #2), the hanging ball of the fan will not fit properly in the canopy. This will cause your fan to rock. A rocking fan CAN NOT be balanced. Any movement in your hanger assembly, as shown in (Fig #1), will cause your fan to rock. If you have 1/8 inch of movement, by the time this amount of movement gets to the bottom of the light kit, you could see as much as 2 inches of side to side rocking of the fan, as shown in (Fig #5) at the bottom of this page. The solution to this problem is to install an extension box, as shown in (Fig #3). An extension box will give you the clearance that is needed to hang your fan correctly as shown in (Fig #4)

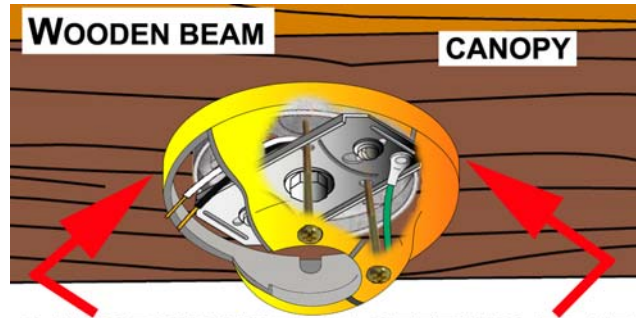

CANOPY MUST BE SETTING FLAT TO THE WOODEN BEAM

(Fig #1)

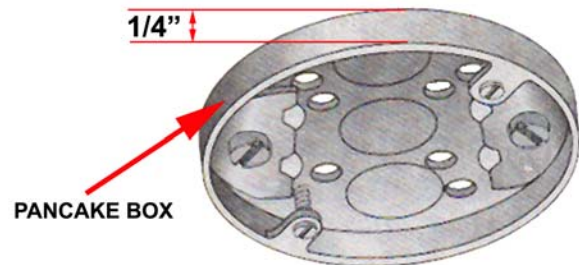

(Fig #2)

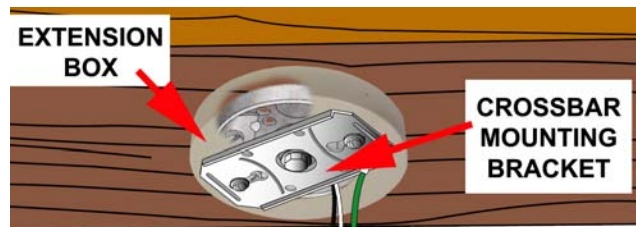

(Fig #3)

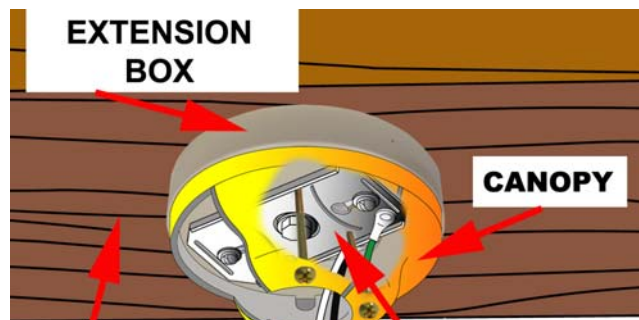

(Fig #4)

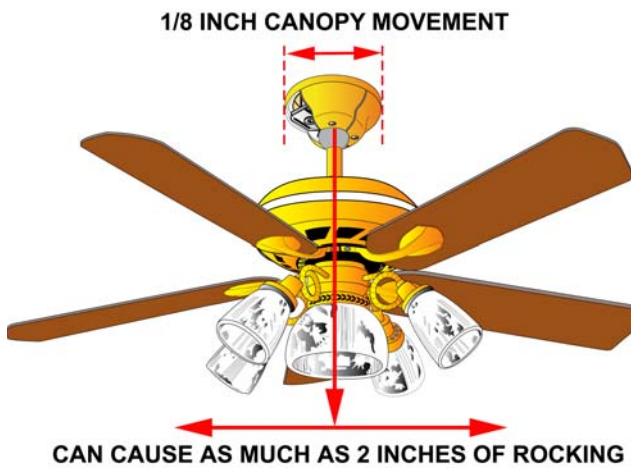

(Fig #5)