

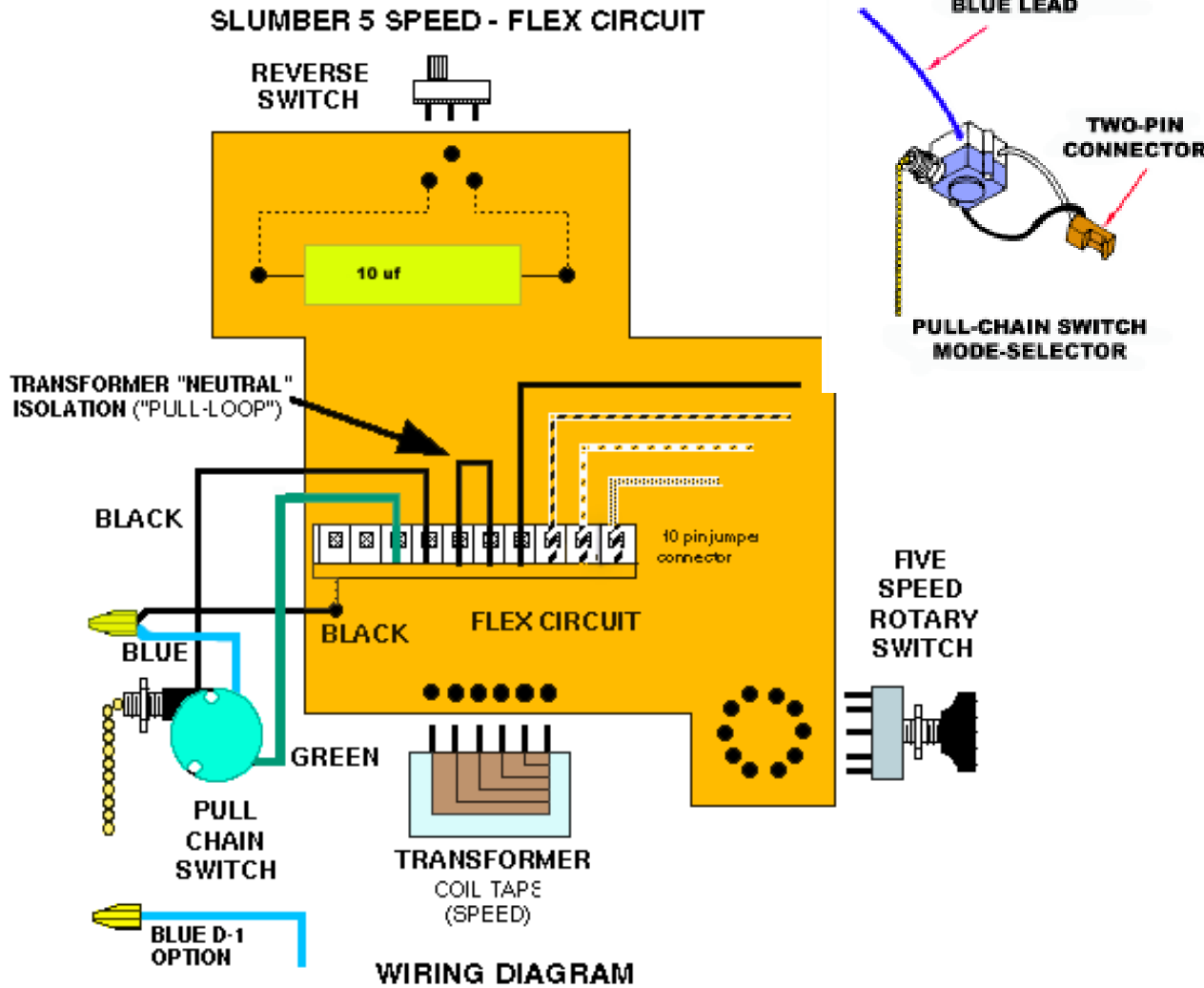

5 SPEED FLEX OPERATION (Page 1 of 2)



DESCRIPTION

The pull chain switch is mounted in the switch housing and controls the mode of operator the fan and light. The pull chain switch turns the fan ON and OFF as follows: one pull, fan OFF; two pulls, fan ON; three pulls, fan OFF; four pulls, fan ON. When the pull chain switch is used in conjunction with an optional light kit, it also turns the light(s) ON and OFF as follows:

- One pull, both the fan and light OFF;
- Two pulls, only the fan ON;
- Three pulls, only the light ON;
- Four pulls, both the fan and light ON.

OPERATION CHART

PULL #	FAN	LIGHT
#1	OFF	OFF
#2	ON	OFF
#3	OFF	ON
#4	ON	ON



5 SPEED FLEX OPERATION (Page 2 of 2)

SLUMBER 5 SPEED - FLEX CIRCUIT

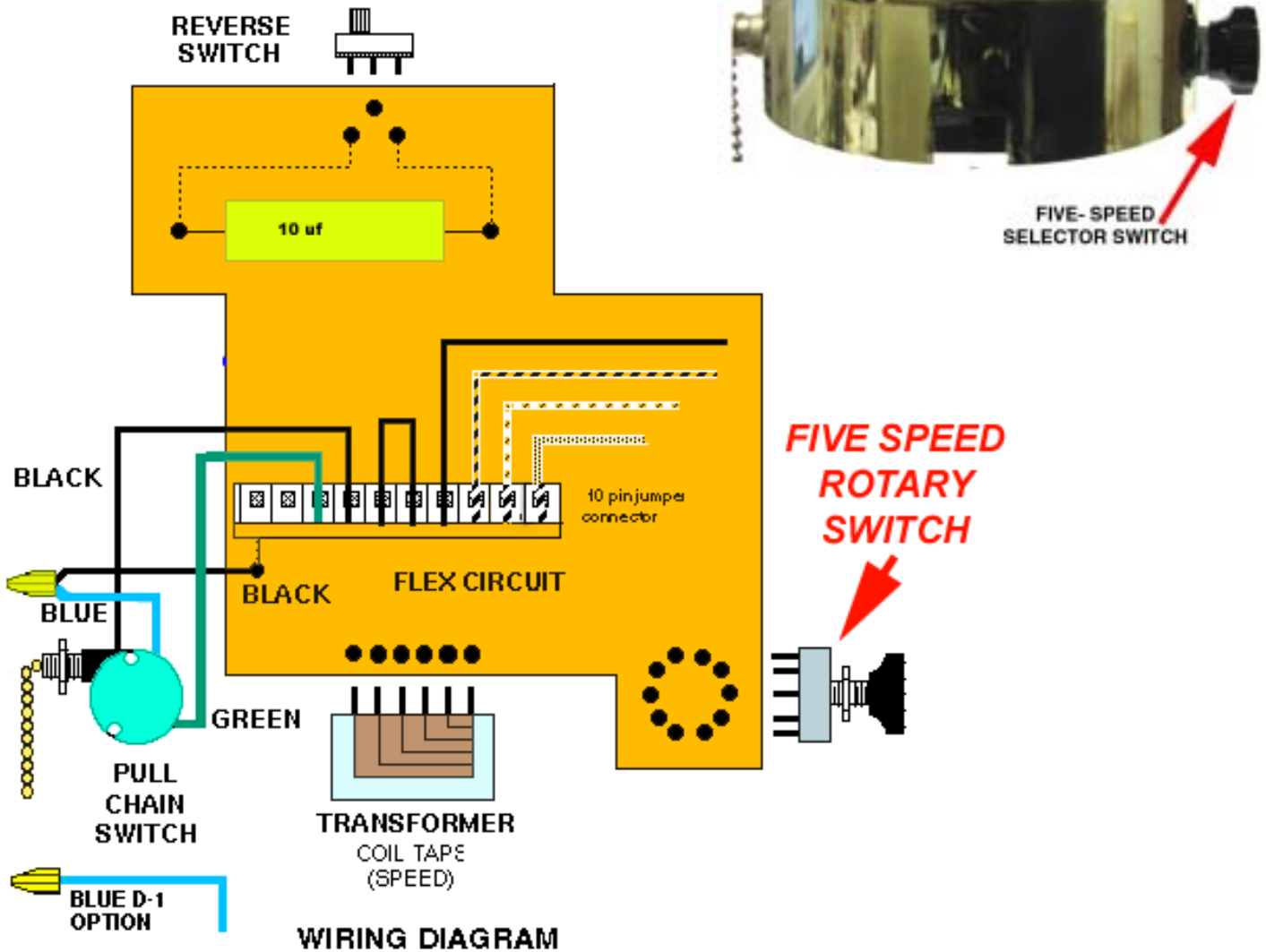

DESCRIPTION

The speed selector switch routes output voltages from various taps of the system transformer to the fan motor via the reverse switch. In response, the fan motor rotates at five specific speeds ranging from minimum to maximum. With the speed selector switch in the extreme counter-

clockwise position, the fan operates at minimum speed, approximately 20 revolutions per minute (rpm). As the switch is rotated clockwise, fan speed is increased to approximately 210 rpm, assuming the fan is equipped with long blades.